



Copies of the I/B. Please reproduce them without any changes except under special instruction from Team International BELGIUM. The pages must be reproduced and folded in order to obtain a booklet A5 (+/- 148.5 mm width x 210 mm height). When folding, make sure you keep the good numbering when you turn the pages of the I/B. Don't change the page numbering. Keep the language integrity. **Print only what is inside the frame.**



KALORIK



www.KALORIK.com



Baby Food Maker

Chopper and

Food Steamer

USK MCH 33526

120V~60Hz 470W (300W+170W)



Front cover page (first page)

Assembly page 1/28



(EN) OPERATING INSTRUCTIONS

IMPORTANT SAFEGUARDS

When using electrical appliances, basic safety precautions should always be followed, including the following:

- ❑ **READ ALL INSTRUCTIONS**
- ❑ Check that your mains voltage corresponds to that stated on the appliance.
- ❑ Close supervision is necessary when any appliance is used by or near children.
- ❑ Do not touch hot surfaces. Use handles or knobs.
- ❑ To protect against electrical shock do not immerse cord, plugs, or the appliance in water or other liquid.
- ❑ Unplug from outlet when not in use, before cleaning and before putting on or taking off parts or before cleaning. Allow to cool before putting on or taking off parts.
- ❑ Do not operate any appliance with a damaged cord or plug or after the appliance malfunctions or has been damaged in any way. Return appliance to the service facility for examination, repair, or adjustment.
- ❑ The use of accessory attachments not recommended by the appliance manufacturer may cause injuries.
- ❑ Do not use outdoors.
- ❑ Do not let cord hang over edge of table or counter, or touch hot surfaces.
- ❑ Do not place on or near a hot gas or electric burner, or in a heated oven.
- ❑ Extreme caution must be used when moving an appliance containing hot oil or other hot liquids.
- ❑ Always attach plug to appliance first, then plug cord into the wall outlet. To disconnect, put the switch in off position, then remove plug from wall outlet.
- ❑ Do not use appliance for other than intended use.
- ❑ This kind of appliance cannot function continuously; it is not a professional type of appliance. It is necessary to make temporary stops. Check the section "Important information" in the instruction manual.



- ❑ It is absolutely necessary to keep this appliance clean at all times as it comes into direct contact with food.
- ❑ The bowl should be assembled correctly on the motor base before you plug it into the mains. The appliance is equipped with a safety, which prevents the motor from working if it the appliance is not assembled correctly.
- ❑ Keep hands and utensils out of container while operating to reduce the risk of severe personal injury and/or damage to the appliance. A rubber spatula may be used but must be used only when the appliance is not running.
- ❑ To reduce the risk of injury, never place the cutting unit blades on base without the bowl properly installed.
- ❑ Always close the bowl with the lid before starting the operation.
- ❑ Install blades properly and cautiously. Injury can result if moving blades accidentally become exposed.
- ❑ Blades are sharp, handle with care.
- ❑ Always operate the appliance with lid in place. Be certain cover is securely locked in place before operating appliance.
- ❑ Never touch the hot parts of the appliance during cooking. The translucent containers are parts of the appliance with hot surfaces. You must use their handles when handling them.
- ❑ Only water should be in the tank where the heating element is. Never place food in it.
- ❑ Do not leave the appliance unattended while it is operating.
- ❑ To disconnect cord, turn the speed selector to "0", then remove the plug from wall outlet.
- ❑ Avoid contacting moving parts.
- ❑ Do not blend hot liquids.
- ❑ After use and above all when the water hasn't completely evaporated, wait until the steam stops pouring, and then open the lid carefully in order not to hurt you. Let the water drip into main tank. Slightly move the lid so that the steam does not reach your hands or your face.
- ❑ Do not attempt to defeat the cover interlock mechanism.
- ❑ Do not open the cover until blades stop.
- ❑ Be cautious while transporting your appliance filled with hot food, water or other liquids. It is not recommended to move your appliance when it has not completely cooled down.



SAVE THESE INSTRUCTIONS HOUSEHOLD USE ONLY

POLARIZED PLUG INSTRUCTIONS

This appliance has a polarized plug (one blade is wider than the other). To reduce the risk of electric shock, this plug will fit into the polarized outlet only one way. If the plug does not properly fit into the outlet at first, reverse it. If it still does not fit, contact a qualified electrician. **Do not attempt to modify the plug or socket in any way.**

SHORT CORD INSTRUCTIONS

A short power supply cord is provided to reduce the hazards resulting from becoming entangled in, or tripping over a longer cord. Extension cords may be used if care is exercised in their use.

- The electrical rating of the extension cord should be at least that of the appliance. If the electrical rating of the extension cord is too low, it could overheat and burn.
- The resulting extended cord should be arranged so that it will not drape over the counter top or tabletop where it can be pulled on by children or tripped over.

SPECIFIC INSTRUCTIONS AND WARNINGS

- The double blade knife is sharp. Handle carefully.
- The bowl must be installed correctly in place before putting the blades in place.
- This appliance is intended for the processing of small quantities of food, for immediate consumption, and is especially recommended for the preparation of baby food. This appliance is not intended to prepare large quantities of food at one time.
- Do not touch hot surfaces. Use handles or knobs.



Copies of the I/B. Please reproduce them without any changes except under special instruction from Team International BELGIUM. The pages must be reproduced and folded in order to obtain a booklet A5 (+/- 148.5 mm width x 210 mm height). When folding, make sure you keep the good numbering when you turn the pages of the I/B. Don't change the page numbering. Keep the language integrity. **Print only what is inside the frame.**



- Do not place in or near a hot gas or electric burner, or in a heated oven.
- To disconnect, turn any control to "Off", then remove the plug from the wall outlet.
- Do not use appliance for other than intended use.
- Before serving, unplug the cord from wall outlet and dish. Do not leave cord within children's reach.



PART DESCRIPTION

1. Rotary Switch Knob
2. Steam function indicator light
3. Blending/Chopping function indicator light
4. OFF position
5. Boiler Cap
6. Steam Hole
7. Roller Rod with security switch
8. Base Unit

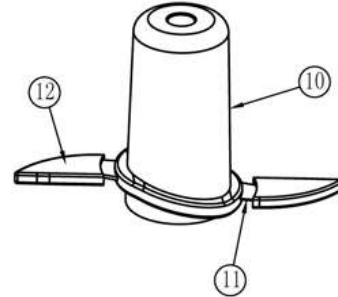

10. Blade unit
11. Blade
12. Protection cover

20. Milk container
21. Milk container lid
22. Milk container lid

35. Spatula
36. Cleaning brush
37. Measuring cup

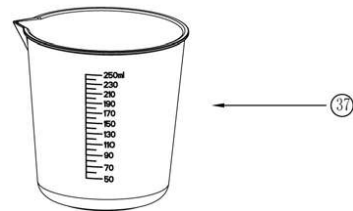
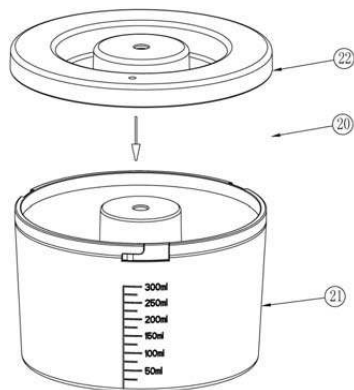
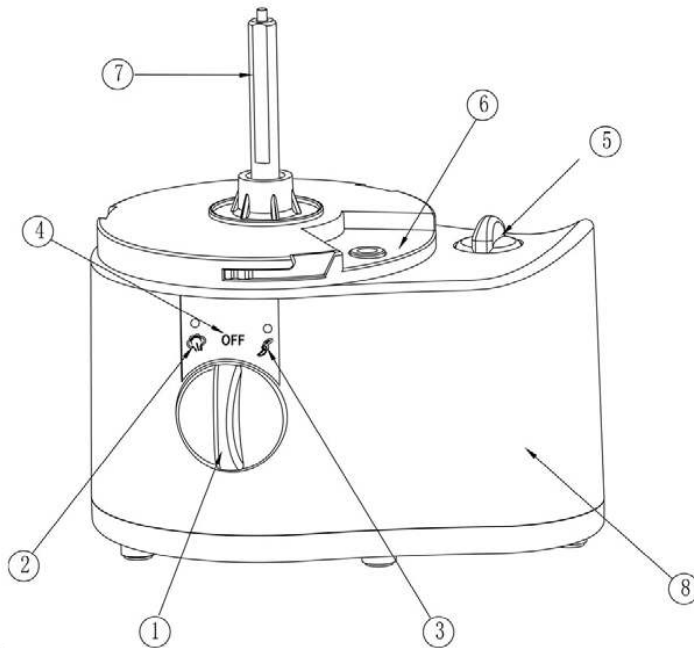



- 31. Mixing container lid
- 32. Soother stand
- 33. Cooking container
- 34. Blending/Chopping container

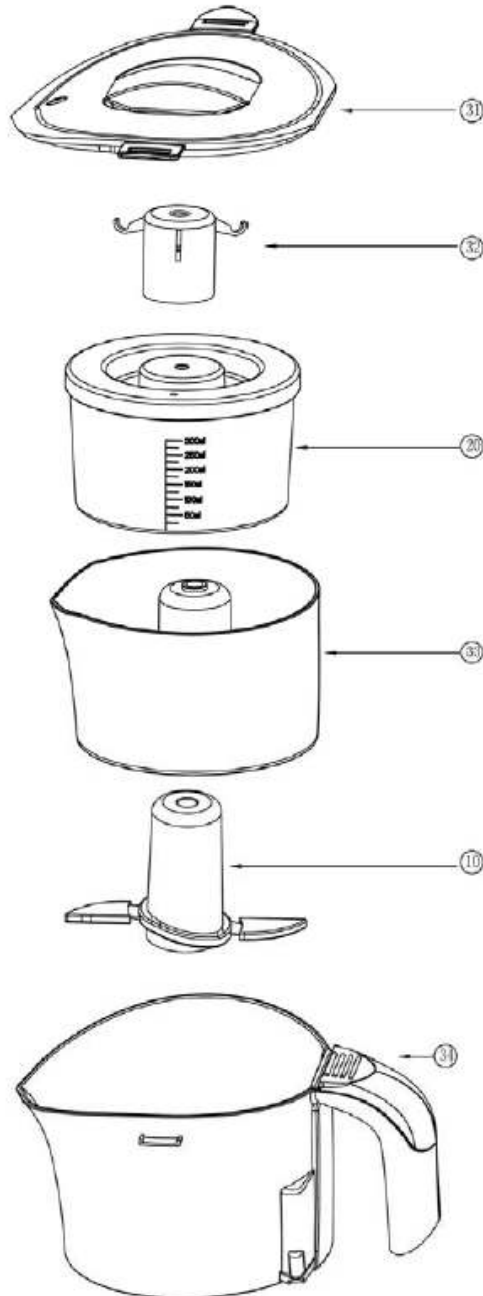



KNOW YOUR APPLIANCE

Your Kalorik baby food maker is a multi-function appliance. It can steam-cook food, blend or chop food, warm up food; milk and liquids, sterilize soothers. It offers the following specifications:

- ❑ By steam-cooking, it offers a healthy, speedy and tasty way to cook for your baby.
- ❑ Extremely high speed blade to grind food in very fine pieces.
- ❑ Powerful steam to cook food in very short time.
- ❑ Simple operation, only 2 switches for whole process.
- ❑ By using high temperature food grade PP (Polypropylene) material and specially formulated plastics, it offers a BPA- and phthalates-free appliance that protects your baby from harmful chemicals.
- ❑ Easy cleaning.
- ❑ Double Thermal cut-off protection by a thermostat and a temperature fuse.
- ❑ Large 230cc / 8 Fl.Oz. water tank provides 30 minutes steam time, long enough steam time for processing every kind of food and quantity.
- ❑ Comes with a milk container, use it to warm up milk or liquids.
- ❑ Comes with a soother stand for the sterilization of soothers.
- ❑ All parts in contact with food are FDA approved, and have been tested BPA- and Phthalates-free.

BEFORE USE

- ❑ Remove the base unit and its accessories from the packaging.
- ❑ Check the base unit and its accessories are not damaged. Should any items be damaged, do not use the unit. Contact a qualified technician.
- ❑ Make sure the unit's voltage rating (shown on rating label on bottom plate of Base Unit) is the same as the AC mains power.
- ❑ Thoroughly wash all items except the base unit before use.
- ❑ All items coming into contact with foodstuff should always be cleaned thoroughly before and after use.
- ❑ Read carefully the instruction manual, pay attention on any warnings before use.



HOW TO USE THE UNIT

Pouring water to Boiler

- ❑ Unplug power cord from AC mains.
- ❑ Unfasten the boiler cap from the base unit by turning it anti-clockwise to "  " and lift it, as shown in fig (a)

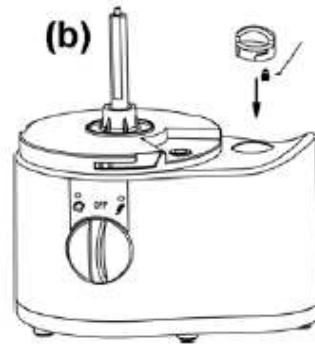
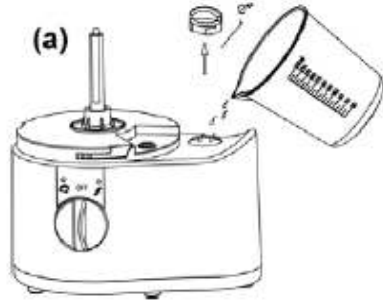

- ❑ Check the boiler is empty by turning the Base Unit upside down and found no water comes out.
- ❑ Clean the boiler if necessary, refer "How to clean the boiler" for cleaning.
- ❑ Use only drinkable water and refer to the "Steam Table" for volume of water to be filled-in
- ❑ We recommend to use purified or distilled water to minimize the amount of mineral deposit that will else build-up inside the boiler.
- ❑ Fill water into Measuring Beaker up to desired "min" marking.
- ❑ Pour water into the boiler carefully, as shown in fig (a)
- ❑ Secure the Cap on Boiler by turning it clockwise to "  ", as shown in fig (b)

Warning!

- ❑ To meet hygiene requirements, do not use any other liquid to fill the boiler. Use water only



- ❑ Never overfill the boiler; never pour water more than 230ml / 8 Fl.Oz.
- ❑ Always fasten the boiler cap firmly in clockwise direction to the  "position.
- ❑ Always unplug power cord before pouring water.

Always check the followings before operating the unit:

- ❑ The protection covers have been removed from blades.
- ❑ The boiler has been filled with water.
- ❑ The boiler cap is secured firmly on the base unit.
- ❑ Then switch knob is in "OFF" position.
- ❑ The blending container is locked firmly on the base unit.
- ❑ The blending container lid is locked.

How to steam-cook food

- ❑ Refer to the "Pouring water to Boiler", pour right amount of water in boiler.
- ❑ Place the blending container into the base unit and secured it firmly by turning it in the direction as shown in fig. (c); make sure the two "arrows" are in line.
- ❑ Place the cooking container in the blending container (as shown in fig. (d))
- ❑ Place **diced or sliced** food in suggested sizes not bigger than ½ inch thickness into the cooking container. Do not fill the container excessively, and avoid pressing on the food.
- ❑ Put the lid on and lock the clips. (fig (e))
- ❑ Make sure the switch knob is in "OFF" position.
- ❑ Plug the power cord into the power socket.
- ❑ Turn the switch knob to  " position, the boiler is then operating and the red light is on.
- ❑ Steam will be filling the container after a few minutes.
- ❑ Boiler will stop automatically at desired time and red light will go off. Turn the switch knob to "OFF". If the boiler does not turn off automatically after desired time, turn the switch knob to "OFF"
- ❑ Important: If the switch knob is not turned to "OFF", the boiler may activate again and then cut off in cycle.



- ❑ Leave the appliance cool for 3 to 5 minutes if necessary.
- ❑ Remove the Blending Container from Base Unit. (fig. f)
- ❑ Open the Lid.

Warning! Take care when opening the lid as steam can be scalding hot.

Remove the food container: food is ready to eat or to be blended
The cooking water on the blending container can be disposed of.

Warning!

- ❑ Containers, lid and food are hot; take care when handling them after cooking.
- ❑ Never switch on the boiler unless the blending container is secured in the right position.
- ❑ Never switch on the boiler unless it is filled with water.
- ❑ Take care: hot steam comes out from steam hole and around of the lid during steaming.
- ❑ Always clean the boiler and all parts immediately after each cooking operation, if you are not going to blend food.

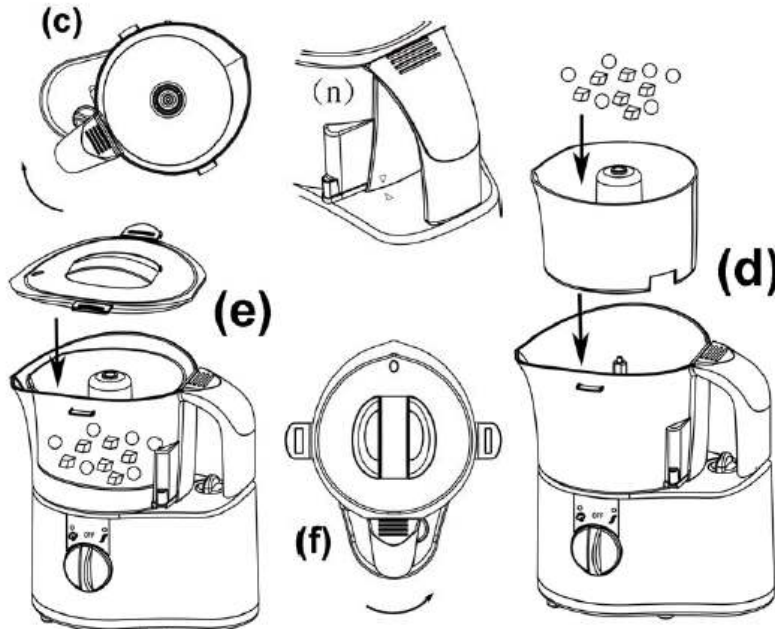



How to blend/chop food

- ❑ Place the blending container on to base unit (fig. c).
- ❑ **Remove** the protection covers from the blade unit
- ❑ Hold the blade unit carefully and insert it on the roller rod (fig. g). Make sure the blade unit is in the right position, until hearing a "click" sound.
- ❑ Place the cooked food in the blending container (fig. h)

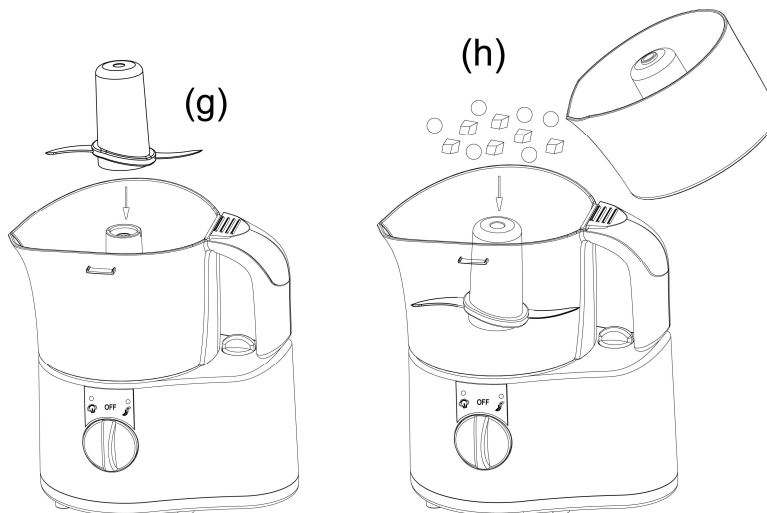

- ❑ Put the lid on and lock the side clips. (fig. e)
- ❑ Turn and hold the switch knob to "  " position for approximately 15 seconds, a blue light is lit during the operation, indicating that the chopper is operating
- ❑ Repeat the chopping cycle if necessary, noting that it is recommended to wait at least 15 seconds between each chopping cycle.
- ❑ Some foodstuff may be stuck on the wall of the blending container or on the Lid, it may use the spatula to remove foodstuff down between each blending cycle.
- ❑ Remove the Blending container from the base unit and take off the lid.
- ❑ Remove the Blade unit very carefully.



- ❑ Remove the food from the container with the spatula.
- ❑ Let your baby enjoy tasty and healthy food!

Warning!

- ❑ Always check the food's temperature before feeding your baby.
- ❑ It is recommended to wait at least 15 seconds between each blending/chopping cycle.
- ❑ Do not blend if the container is empty.
- ❑ Do not add too much liquid to be blended with the food to avoid splatter
- ❑ Do not blend or chop frozen food, or food with bones or hard parts.

How to warm up and defrost food

- ❑ Follow "How to steam cooking food" to warm up and defrost food.
- ❑ Important information regarding the steaming time—it is only for reference purposes. The steaming time is may vary depending on the weight and temperature of the food.
- ❑ We recommend pouring 230ml / 8 Fl.Oz. water, then to check the food status after 5min for a small amount of food, 10min for a medium quantity of food, and 15min for large volume of food. Sample the food by using a spoon or a fork, in order to check the cooking level.

Warning!

- ❑ Never overfill the boiler; never pour water more than 230ml / 8 Fl.Oz.
- ❑ Take care when opening the lid, as steam can be scalding hot.
- ❑ Take care; hot steam comes out from the steam hole and from the edges of the lid during steaming.
- ❑ Take care when removing containers, lid and food, as they are hot, steam can be scalding.
- ❑ Always check the food temperature before feeding your baby

How to warm up milk or liquid

- ❑ Open the lid from the milk container. (fig. (i))
- ❑ Pour milk or liquid into the milk container (fig. (i)) and close the lid.



- ❑ Refer to the "Pouring water into the boiler" section, pour the right amount of water in the boiler for the steaming time desired.
- ❑ Place the blending container in the base unit and secure it firmly by turning it in the direction as shown in fig. (c) and (n).
- ❑ Place the milk container in the blending container.
- ❑ Repeat the steps explained in "**How to steam-cook food**".
- ❑ Remove the milk container; the contents are ready for drinking.

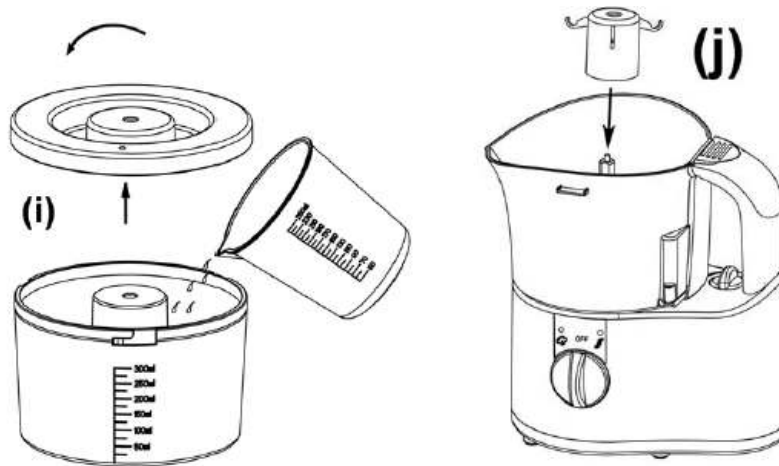

Warning!

- ❑ Containers and lid are hot, take care when handling them.
- ❑ Check the temperature of the milk or liquids by sprinkling a few drops on to your wrist before you start feeding your baby

How to sterilize soothers

- ❑ Pour 60ml / 2 Fl.Oz. of water into the boiler for 8 min. steaming time.
- ❑ Place the blending container in the base unit and secure it firmly by turning it in the direction as shown in fig. (c) and (n).
- ❑ Place the soother stand on top of the Roller Rod. Like in fig. (j)
- ❑ Hang soothers on the Soother Stand.
- ❑ Repeat the steps explained in "How to steam-cook food".
- ❑ Take out the sterilized soothers carefully.

Warning!

Containers, soothers and Lid are hot, take care when handling them.



CLEANING AND MAINTENANCE OF THE UNIT

Cleaning the base unit

- Always unplug the unit and make sure it is cold before cleaning it.
- Do not immerse the base unit in water
- Clean the base unit with a damp cloth only.
- Do not attempt to clean the base unit with any abrasives or cleaning solvent as this may cause damage to the unit.

Warning!

- Always unplug the unit and make sure it is cold before cleaning it.
- Switch off the appliance and disconnect from supply before changing accessories or approaching parts which move during use.

Cleaning the blade unit

- Remove the blade unit from the container
- Rinse it thoroughly and remove any food residues.
- Clean it with soapy water or with a neutral detergent.
- Rinse it thoroughly and dry it immediately.
- Put covers on and keep it out of reach of children.

Warning!

- Always handle it very carefully as blades are very sharp.
- Always put covers on when unattended.
- Never use bleaching agents or Chlorine based detergents as they may damage the blades.
- Do not to put the blades in a dishwasher.

Cleaning the boiler

After each operation

- Always unplug the unit and make sure it is cold before cleaning the boiler.
- Unfasten the boiler cap from the base unit by turning it anti-clockwise and lift it. (fig. a)
- Check that the boiler is empty by turning the base unit upside-down and see that no water comes out. (fig. k)

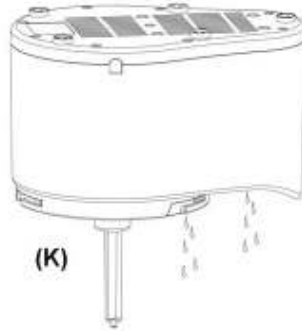

- ❑ Fill 230ml / 8 Fl.Oz. water into the measuring beaker.
- ❑ Pour water into the boiler carefully. (fig. a)
- ❑ Secure the cap on the boiler by turning it clockwise. (fig. b)
- ❑ Shake the base unit several times in different directions.
- ❑ Unfasten the boiler cap and empty the boiler in a sink.
- ❑ Repeat the above mentioned steps if necessary.

Warning! Always unplug the unit and make sure it is cold before cleaning the boiler.

Routine Maintenance of the boiler

- ❑ Mineral deposit will settle down inside the boiler in normal use. It may be better to use pre-boiled or filtered water in your baby Food maker in order to reduce the mineral deposit and the need to decalcify.
- ❑ On a regular basis, the residues can be removed by using a white vinegar solution. Approximately 230ml / 8 Fl.Oz. of a white vinegar solution (in a ratio of 1:4, meaning 1 part of vinegar to 4 parts of water) should be poured into the boiler and left for 2 hours. The solution should then be removed, rinsed and dried off.
- ❑ Perform a steaming cycle by using 230ml / 8 Fl.Oz. water with the empty blending container only.
- ❑ The cleaning process is recommended to be carried out at regular intervals—at least once every 2 weeks if using hard water

Warning!
Always unplug the unit and make sure it is cold before cleaning it.



Cleaning plastics parts

- ❑ All plastics parts should be cleaned after each operation.
- ❑ Rinse them (except the base Unit) thoroughly and remove any food residues.
- ❑ Hand-wash them with a little mild liquid detergent or neutral detergent.
- ❑ Rinse thoroughly and dry immediately.

Cleaning the blending container

- ❑ Rinse it thoroughly and remove any food residues after each use.
Note: the filter/steam hole is now embedded on a **sliding tab** that enables an easier access and cleaning of the steam chamber, and of the filter itself.
- ❑ Make sure the steam hole/filter (l) has no residues stuck, clean by using the brush.
- ❑ Hand-wash the Container (m) with a little mild liquid detergent or neutral detergent.
- ❑ Rinse it thoroughly and dry it immediately.
- ❑ Make sure there are no residues inside the steam chamber. Repeat steps 3 and 4 if necessary.

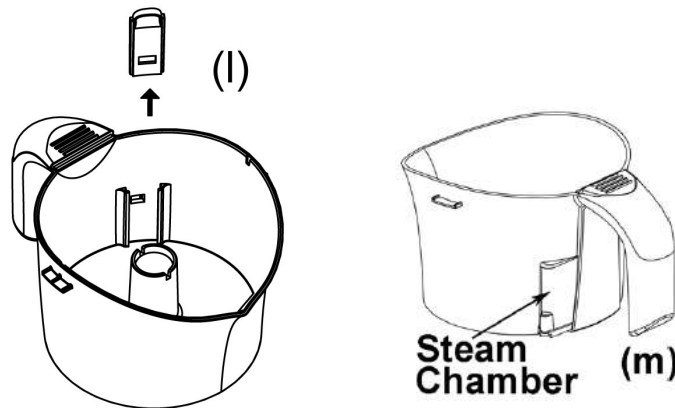

Note: Dishwashing safety

The blending container, steam container, milk container, spatula, measuring beaker, brush and top cover have also passed the dishwashing safety test, so alternatively to hand-washing, you can safely wash all plastic parts in the dishwasher too.



STEAMING TIMES

- ❑ The steaming times below are for reference only and should be adjusted to food quantity or desired temperature.
- ❑ The steam times mentioned are "net" steaming time. Add 1 to 3 minutes for the total process, as it may take 1 to 3 minutes for steam to start being generated.
- ❑ Always check that food is cooked and drinks are brought to the desired temperature before feeding your baby.
- ❑ Fill water in the beaker and use the tables below for the steaming times:

For steam cooking

Water volume	Steaming time
40ml / 1.3 Fl.Oz.	5 min.
70ml / 2.3 Fl.Oz.	10 min.
110ml / 3.7 Fl.Oz.	15 min.
140ml / 4.7 Fl.Oz.	20 min.
180ml / 6 Fl.Oz.	25 min.
230ml / 8Fl.Oz.	30 min.

For steam-warming liquids (in the milk container)

Liquid starting at room temperature

Quantity of milk	Water in boiler	Steaming time
120ml / 4 Fl. Oz.	30ml / 1 Fl.Oz.	2 ½ min.
180ml / 6 Fl.Oz.	35ml / 1.2 Fl.Oz.	3 ½ min.
240ml / 8 Fl.Oz.	40ml / 1.4 Fl.Oz.	4 ½ min.

For steam-warming liquids (in the milk container)

Liquid starting at refrigerator temperature

Quantity of milk	Water in boiler	Steaming time
120ml / 4 Fl. Oz.	30ml / 1 Fl.Oz.	3 ½ min.
180ml / 6 Fl.Oz.	40ml / 1.4 Fl.Oz.	4 ½ min.
240ml / 8 Fl.Oz.	45ml / 1.6 Fl.Oz.	5 min.

For sterilizing soothers

Water volume	Steaming time
60ml / 2 Fl.Oz.	8 min.



Food cooking guide

Food (100g/3 ½ Oz)	Water volume	Steaming time
Leeks	70ml / 2 ½ Fl. Oz.	10 min.
Spinach	70ml / 2 ½ Fl. Oz.	10 min.
Zucchini	70ml / 2 ½ Fl. Oz.	15 min.
Carrots	140ml / 5 Fl.Oz.	20 min.
Cauliflower	140ml / 5 Fl.Oz.	20 min.
Green beans	140ml / 5 Fl.Oz.	20 min.
Peas	140ml / 5 Fl.Oz.	20 min.
Potatoes	140ml / 5 Fl.Oz.	20 min.
Turnips	140ml / 5 Fl.Oz.	20 min.
Pumpkin	140ml / 5 Fl.Oz.	20 min.
Apple	70ml / 2 ½ Fl. Oz.	10 min.
Pear	70ml / 2 ½ Fl. Oz.	10 min.
Pineapple	70ml / 2 ½ Fl. Oz.	10 min.
Strawberry	70ml / 2 ½ Fl. Oz.	10 min.
Fish	70ml / 2 ½ Fl. Oz.	10 min.
Chicken	180ml / 6 Fl.Oz.	25 min.
Pork	180ml / 6 Fl.Oz.	25 min.
Veal/Beef	180ml / 6 Fl.Oz.	25 min.

Warning!

- ❑ Always check food temperature before feeding your baby.
- ❑ Check the temperature of the milk/liquids by sprinkling a few drops on to your wrist before you feed your baby.
- ❑ Always dice or slice food before cooking with the baby food maker.
- ❑ The steaming times shown on the above tables are for reference only. The steam cooking time is depending on the quantity, temperature and kind of food you prepare.



TROUBLESHOOTING

- In case of no function:
 1. Please check first that the appliance is plugged in.
 2. Then make sure that the bowl and lid are locked correctly in place. Micro-switches will prevent operation if not.
 3. Please make sure the lid is not deformed and presses on the upper part of the Roller Rod with security switch.

- If food enters the steam chamber of the bowl:
 1. Remove the tab with the filter/steam hole by sliding it out. Let water drain inside the steam chamber through the hole. Use a small brush whenever needed to get rid of any residue.

- While chopping, it may happen that food is projected on the side of the container, thus giving a unsatisfactory result and food being not chopped finely enough / not pureeing. In this case:
 1. Try chopping larger quantities.
 2. Increase the steaming time, the vegetables need to be fork-tender to puree well.
 3. Try adding a bit more liquid; this should enable a smoother, less dry, preparation.



Copies of the I/B. Please reproduce them without any changes except under special instruction from Team International BELGIUM. The pages must be reproduced and folded in order to obtain a booklet A5 (+/- 148.5 mm width x 210 mm height). When folding, make sure you keep the good numbering when you turn the pages of the I/B. Don't change the page numbering. Keep the language integrity. **Print only what is inside the frame.**



WARRANTY

We suggest that you complete and return the enclosed Product Registration Card promptly to facilitate verification of the date of original purchase. However, return of the Product Registration Card is not a condition of these warranties. You can also fill this warranty card online, at the following address: www.KALORIK.com

This KALORIK product is warranted in the U.S.A. for 1 year from the date of purchase against defects in material and workmanship. This warranty is not transferable. Keep the original sales receipt. Proof of purchase is required to obtain warranty performance.

During this period, the KALORIK product that, upon inspection by KALORIK, is proved defective, will be repaired or replaced, at Kalorik's option, without charge to the customer. If a replacement product is sent, it will carry the remaining warranty of the original product.

This warranty does not apply to any defect arising from a buyer's or user's misuse of the product, negligence, failure to follow KALORIK instructions noted in the user's manual, use on current or voltage other than that stamped on the product, wear and tear, alteration or repair not authorized by KALORIK, or use for commercial purposes. There is no warranty for glass parts, glass containers, filter basket, blades and agitators, and accessories in general. There is also no warranty for parts lost by the user.

ANY WARRANTY OF MERCHANTABILITY OR FITNESS WITH RESPECT TO THIS PRODUCT IS ALSO LIMITED TO THE ONE YEAR LIMITED WARRANTY PERIOD.

Some states do not allow limitation on how long an implied warranty lasts or do not allow the exclusion of incidental or consequential damages, so the above limitations may not apply to you. This warranty gives you specific legal rights, and you may also have other rights which vary from state to state.



Copies of the I/B. Please reproduce them without any changes except under special instruction from Team International BELGIUM. The pages must be reproduced and folded in order to obtain a booklet A5 (+/- 148.5 mm width x 210 mm height). When folding, make sure you keep the good numbering when you turn the pages of the I/B. Don't change the page numbering. Keep the language integrity. **Print only what is inside the frame.**



If the appliance should become defective within the warranty period and more than 30 days after date of purchase, do not return the appliance to the store: often, our Consumer Service Representatives can help solve the problem without having the product serviced. If servicing is needed, a Representative can confirm whether the product is under warranty and direct you to the nearest service location.

If this is the case, bring the product, or send it, postage prepaid by the user (all Kalorik customers are responsible for the initial shipment back to the warranty center), along **with proof of purchase** and indicating a **return authorization number** given by our Consumer Service Representatives, to the authorized KALORIK Service Center (please visit our website at www.KALORIK.com or call our Customer Service Department for the address of our authorized KALORIK Service Center).

If you send the product, please include a letter explaining the nature of the claimed defect.

If you have additional questions, please call our Consumer Service Department (please see below for complete contact information), Monday through Friday from 9:00am - 6:00pm (EST). Please note hours are subject to change.

If you would like to write, please send your letter to:

KALORIK Consumer Service Department
Team International Group of America Inc.
1400 N.W 159th Street, Suite 102
Miami Gardens, FL 33169 USA

Or call:

Toll Free: +1 888-521-TEAM / +1 888-KALORIK

Only letters can be accepted at this address above. Shipments and packages that do not have a return authorization number will be refused.



Copies of the I/B. Please reproduce them without any changes except under special instruction from Team International BELGIUM. The pages must be reproduced and folded in order to obtain a booklet A5 (+/- 148.5 mm width x 210 mm height). When folding, make sure you keep the good numbering when you turn the pages of the I/B. Don't change the page numbering. Keep the language integrity. **Print only what is inside the frame.**



GARANTÍA

Le sugerimos rellenar y nos envíen rápidamente la Tarjeta de Registro de Producto adjunta para facilitar la verificación de la fecha de compra. Por lo tanto, la devolución de esa Tarjeta de Registro de Producto no es una condición imprescindible para la aplicación de esa garantía. Puede también rellenar dicha tarjeta de garantía en línea en la dirección siguiente: www.KALORIK.com

A partir de la fecha de compra, este producto KALORIK está garantizado un año contra los defectos materiales y de fabricación, en los Estados Unidos. Esta garantía no es transferible. Conserve la prueba de compra original. Se exige una prueba de compra para obtener la aplicación de la garantía.

Durante este período, si el producto KALORIK después de una inspección por parte de KALORIK, se manifiesta defectuoso, será reparado o reemplazado, según lo que decida KALORIK, sin gastos para el consumidor. Si se envía un producto de reemplazo, se aplicará la garantía que queda del producto original.

Esta garantía no se aplica a los defectos causados por una mala utilización por parte del comprador o del usuario, o una negligencia al no respeto del manual de instrucciones KALORIK, o una utilización en un circuito eléctrico cuyo voltaje es diferente al que figura en el producto, o un desgaste normal, o modificaciones o reparaciones no autorizadas por KALORIK, o por un uso con fines comerciales. No existe garantía por las partes de cristal, jarras de cristal, filtros, cestos, cuchillas y accesorios en general. No existe tampoco garantía por las piezas perdidas por el usuario.

Toda garantía de valor comercial o de adaptabilidad a este producto está limitada a un año también.

Algunos estados no ponen límites a la duración de la garantía tácita o no autorizan la exclusión de daños y perjuicios accesorios o indirectos, por lo que puede que las restricciones anteriormente mencionadas no le sean aplicables a Usted. Esta garantía le otorga derechos legales particulares, pero usted puede tener también otros



Copies of the I/B. Please reproduce them without any changes except under special instruction from Team International BELGIUM. The pages must be reproduced and folded in order to obtain a booklet A5 (+/- 148.5 mm width x 210 mm height). When folding, make sure you keep the good numbering when you turn the pages of the I/B. Don't change the page numbering. Keep the language integrity. **Print only what is inside the frame.**



derechos que varían de un estado a otro y algunos derechos pueden variar de un estado a otro.

Si el aparato tuviera un defecto durante el periodo de garantía y / o más de 30 días después de que se compró, no devuelva el aparato en la tienda donde le compró: a menudo, nuestro Servicio al Consumidor puede ayudar a resolver el problema sin que el producto tenga que ser reparado. Si hace falta una reparación, uno de nuestros representantes puede confirmar si el producto está bajo garantía y dirigirle al servicio post-venta más próximo.

Si fuera el caso, traiga el producto (o envíelo, correctamente franqueado) con la **prueba de compra** que mencione **el número de autorización de devolución** indicado por nuestro Servicio al Consumidor, al servicio post-venta KALORIK más próximo. (Visite nuestra web www.KALORIK.com o llame al Servicio al Consumidor para obtener la dirección del Servicio post-venta KALORIK exclusivo más próximo).

Si envía el producto, le rogamos añadan una carta explicando la naturaleza del defecto.

Si tiene preguntas adicionales, por favor llame al Servicio al Consumidor (véase abajo para los datos completos), de lunes a viernes, de las 9 a las 18 (EST). Note que las horas pueden ser modificadas.

Si quiere escribirnos, puede hacerlo a la dirección siguiente:

KALORIK Servicio al Consumidor

Team International Group of America Inc.
1400 N.W 159th Street, Suite 102
Miami Gardens, FL 33169 USA

O llame gratuitamente (U.S.A.) al +1 888-521-TEAM / +1 888-KALORIK

Las cartas se aceptan solamente en la dirección anteriormente mencionada. Los envíos y paquetes que no tengan número de autorización de devolución serán rechazados.



Copies of the I/B. Please reproduce them without any changes except under special instruction from Team International BELGIUM. The pages must be reproduced and folded in order to obtain a booklet A5 (+/- 148.5 mm width x 210 mm height). When folding, make sure you keep the good numbering when you turn the pages of the I/B. Don't change the page numbering. Keep the language integrity. **Print only what is inside the frame.**



GARANTIE

Nous vous suggérons de remplir et de nous renvoyer rapidement la Carte d'Enregistrement Produit ci-jointe afin de faciliter la vérification de la date d'achat. Cependant, le renvoi de la Carte d'Enregistrement Produit n'est pas une condition indispensable à l'application de la présente garantie. Vous pouvez aussi remplir cette carte de garantie en ligne à l'adresse suivante : **www.KALORIK.com**.

A compter de la date d'achat, ce produit KALORIK est garanti un an, sur le territoire des Etats-Unis, contre les défauts matériels et de fabrication. Cette garantie n'est pas transférable. Conservez la preuve d'achat originelle. Une preuve d'achat est exigée pour obtenir l'application de la garantie.

Durant cette période, le produit KALORIK qui, après inspection par KALORIK, s'avère défectueux, sera réparé ou remplacé, au choix de KALORIK, sans frais pour le consommateur. Si un produit de remplacement est envoyé, c'est la garantie restante du produit originel qui s'appliquera.

La présente garantie ne s'applique pas aux défauts dus à une mauvaise utilisation de la part de l'acheteur ou de l'utilisateur, à une négligence, au non-respect des consignes du manuel d'utilisation KALORIK, à une utilisation sur un circuit électrique au voltage différent de celui renseigné sur le produit, à une usure normale, à des modifications ou réparations non autorisées par KALORIK, ou par un usage à des fins commerciales. Il n'existe pas de garantie pour les parties en verre, récipients en verre, filtres, paniers, lames et accessoires en général. Il n'existe également pas de garantie pour les pièces perdues par l'utilisateur.

Toute garantie de valeur commerciale ou d'adaptabilité à ce produit est également limitée à la garantie d'un an.

Certains états ne limitent pas la longueur de la garantie tacite ou n'autorisent pas l'exclusion de dommages-intérêts accessoires ou indirects, les restrictions ci-dessus peuvent donc ne pas s'appliquer à



Copies of the I/B. Please reproduce them without any changes except under special instruction from Team International BELGIUM. The pages must be reproduced and folded in order to obtain a booklet A5 (+/- 148.5 mm width x 210 mm height). When folding, make sure you keep the good numbering when you turn the pages of the I/B. Don't change the page numbering. Keep the language integrity. **Print only what is inside the frame.**



vous. Cette garantie vous donne des droits légaux particuliers, et certains droits peuvent varier d'un état à l'autre.

Si l'appareil devait présenter un défaut durant la période de garantie et plus de 30 jours après l'achat, ne ramenez pas l'appareil au magasin : souvent, notre Service Clientèle peut aider à résoudre le problème sans que le produit ne doive être réparé. Si une réparation est nécessaire, un représentant peut confirmer si le produit est sous garantie et vous rediriger vers notre centre de réparation.

Le cas échéant, ramenez le produit (ou envoyez-le, dûment affranchi), ainsi qu'**une preuve d'achat**, en mentionnant **le numéro d'autorisation de retour**, indiqué par notre service clientèle, au service après-vente KALORIK agréé (visitez notre site internet www.KALORIK.com ou appelez notre département Service Clientèle pour obtenir l'adresse du service après-vente KALORIK agréé).

Si vous envoyez le produit, veuillez y joindre une lettre expliquant la nature du défaut.

Si vous avez des questions complémentaires, veuillez appeler notre département Service Clientèle (voyez plus bas pour les coordonnées complètes), du lundi au vendredi de 9h à 18h (EST). Veuillez noter que les heures sont sujettes à modification.

Si vous souhaitez nous écrire, adressez votre courrier à:

KALORIK Consumer Service Department
Team International Group of America Inc.
1400 N.W 159th Street, Suite 102
Miami Gardens, FL 33169 USA

Ou appelez (Gratuitement des Etats-Unis): +1 888-521-TEAM ou +1 888-KALORIK.

Seules les lettres seront acceptées à l'adresse ci-dessus. Les envois et colis n'ayant pas de numéro d'autorisation de retour seront refusés.



Back cover page (last page)

Assembly page 26/28



Copies of the I/B. Please reproduce them without any changes except under special instruction from Team International BELGIUM. The pages must be reproduced and folded in order to obtain a booklet A5 (+/- 148.5 mm width x 210 mm height). When folding, make sure you keep the good numbering when you turn the pages of the I/B. Don't change the page numbering. Keep the language integrity. **Print only what is inside the frame.**

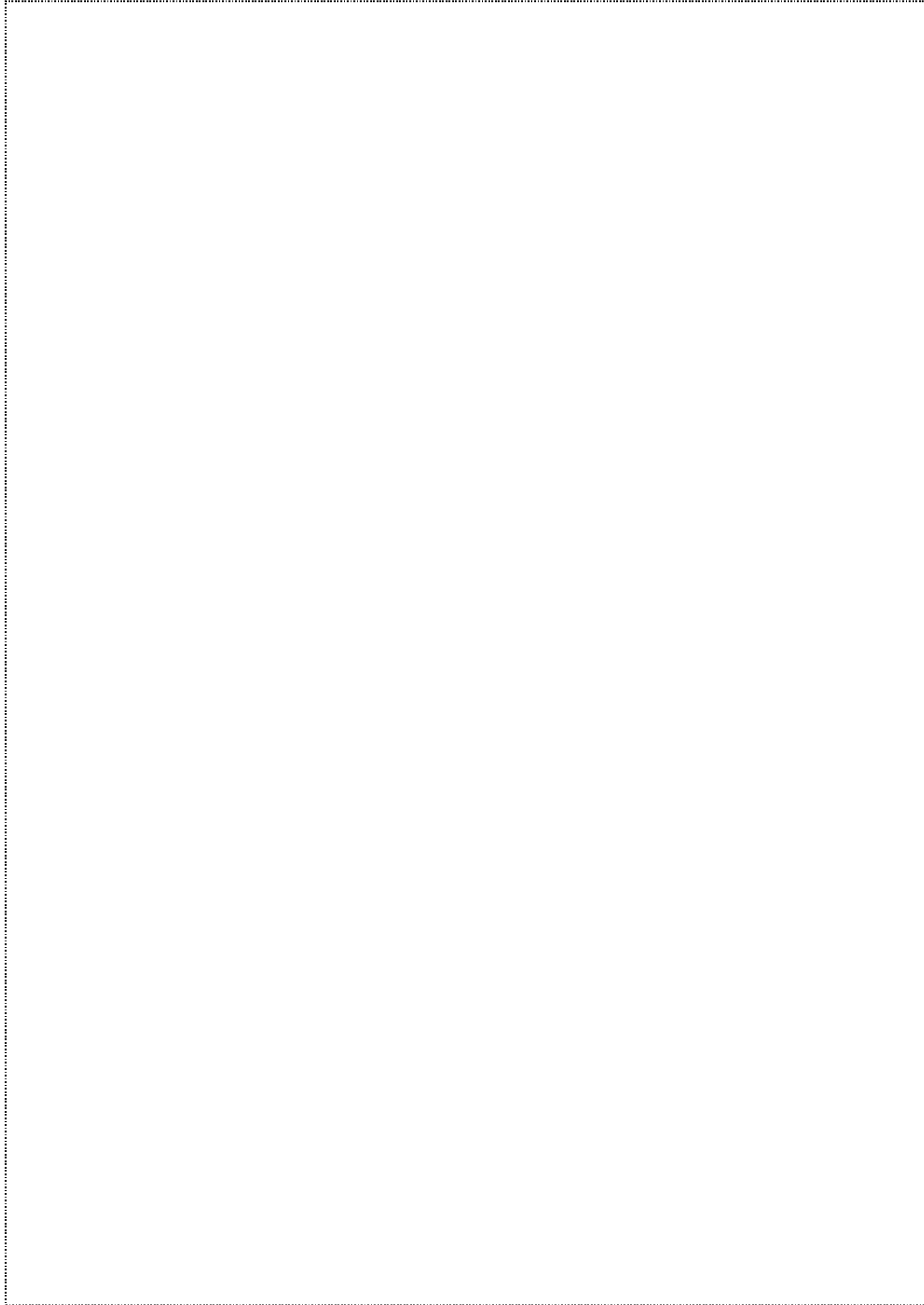

Back cover page (last page)

Assembly page 27/28



Copies of the I/B. Please reproduce them without any changes except under special instruction from Team International BELGIUM. The pages must be reproduced and folded in order to obtain a booklet A5 (+/- 148.5 mm width x 210 mm height). When folding, make sure you keep the good numbering when you turn the pages of the I/B. Don't change the page numbering. Keep the language integrity. **Print only what is inside the frame.**

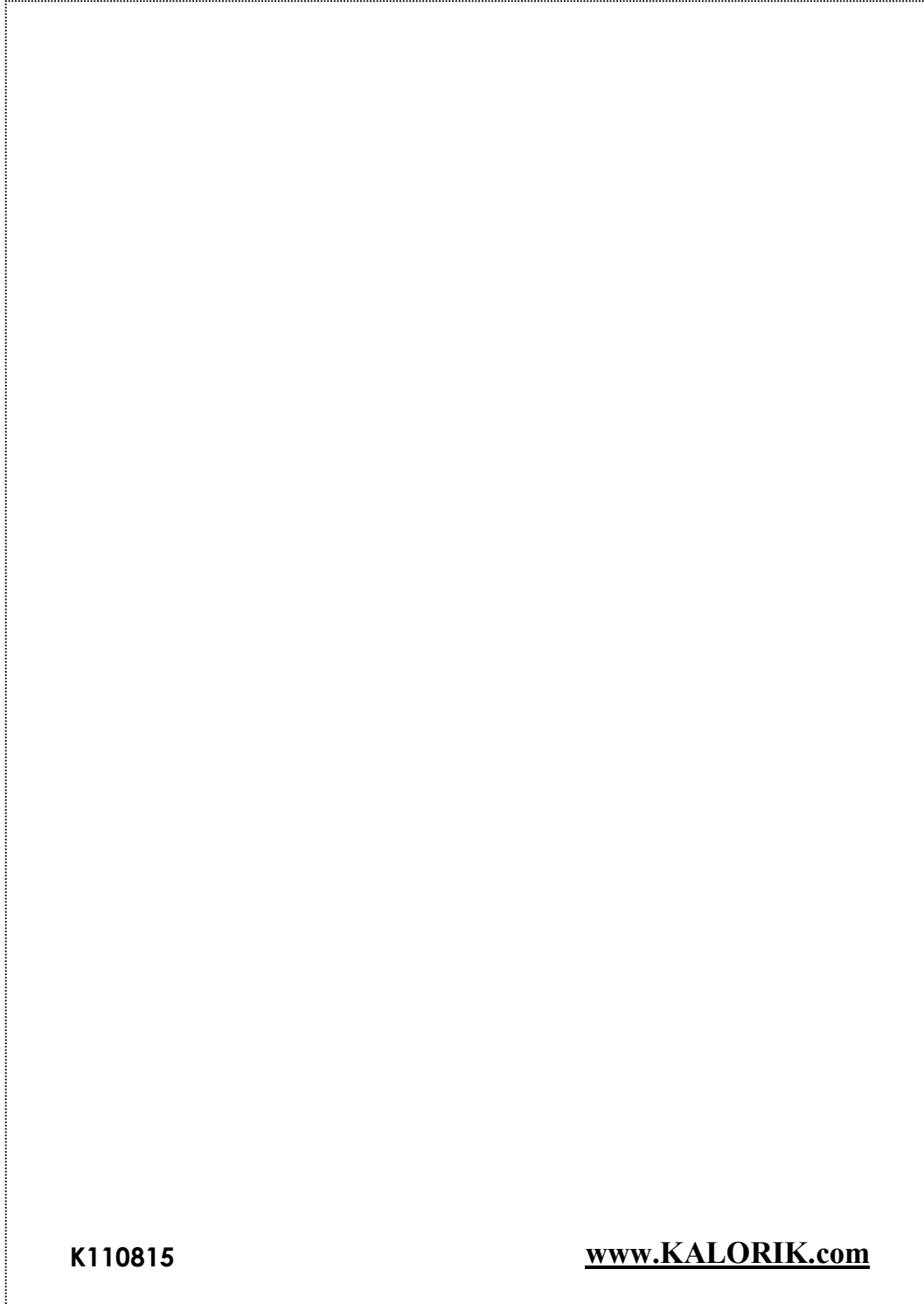

K110815

www.KALORIK.com



Back cover page (last page)

Assembly page 28/28